

Air Conditioning Condensing Units For a Marine Machinery Space Environment

Model # MACU

FEATURES

- ☐ For installations in 115° F ambient temperature
- ☐ Totally enclosed condenser fan motor
- ☐ Steel cabinet with galvanized coating & baked on polyester powder coating
- ☐ External service valves with service ports
- ☐ NEMA 12 control enclosure
- ☐ Standard heavy duty controls
- ☐ Internal temperature and current sensitive compressor protection
- ☐ High / Low pressure controls
- ☐ Heresite[®] coated condenser coil
- ☐ Circuit breaker
- ☐ 208/230-1-60, 208/230-3-60, 460-3-60

SPECIFICATIONS

ASSY. NO:	MACU-3	MACU-4	MACU-5	MACU-7.5	MACU-10
CAPACITY	29,400	41,200	51,200	83,900	103,200
KW	4.2	6.31	7.5	9.2	11.5
REFRIGERANT	R-22	R-22	R-22	R-22	R-22
LIQ. LINE OD	1/2	1/2	1/2	5/8	5/8
SUCT. LINE OD	7/8	7/8	7/8	1-1/8	1-1/8
HEIGHT "C"	26	28	36	42	42
WIDTH "A"	30	30	30	40	40
DEPTH "B"	23	30	30	45	45
WEIGHT (LBS)	141	210	243	480	540

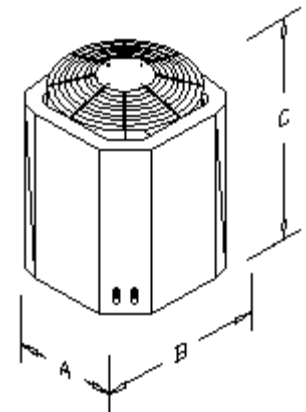

SPECIFICATIONS SUBJECT TO CHANGE WITHOUT NOTICE



NANCE INTERNATIONAL, INC.
 Tel: (409) 838-6127 ♦ Fax: (409) 838-6219
 2915 Milam St., Beaumont, Texas: 77701
 Email: info@nanceinternational.com
 Web: www.nanceinternational.com

- ♦ AIR CONDITIONING
- ♦ REFRIGERATION
- ♦ HEATING
- ♦ VENTILATION

Form: MACU 120203